



Roth MultiTank- Riser Product Directory

Roth Global Plastics

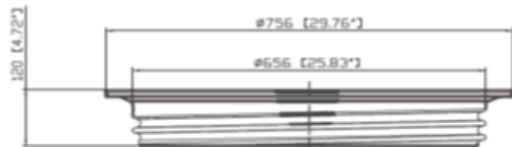
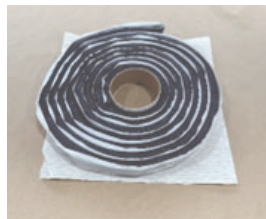
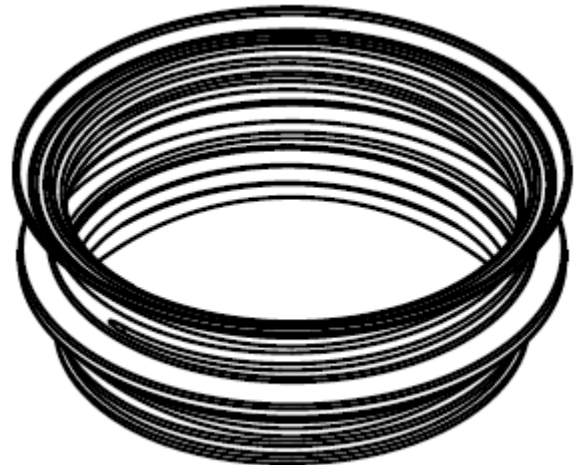

Table of contents:	Page
Roth Risers STAR-24 System	
Roth STAR-24 R6 and R12 Threaded Risers	2-3
Roth STAR-24HPV Hanging Pump Vault	4
Roth Lids and Plugs	
Roth STAR-24L Threaded Lid	5
Roth STAR-24P Non-Threaded Plug	6
Roth STAR-18P Non-Threaded Plug	7
Roth STAR-24SSLA Secondary Safety Lid Assembly	8
Roth Tank Adapter	
Roth STAR-24TA Tank Adapter	9
Roth STAR-18TA Tank Adapter	9
Roth Riser Sealants	
TJ-CS102 ¾" Butyl sealant (rope)	10
RJ-CS212 4" Butyl sealant (wrap)	10
PJ-CS665 ⅝" x ¾" Butyl sealant (rope)	10
RG24 Riser gasket	10
STAR-24P Plug Kit- Tape gasket and security seal	10
Orenco Products available from Roth for Roth RMT Tanks	
OR-ADP 24 in PP Riser/Tank Adapter	11
OR-BDK Orenco Bolt Down Kit	12
ADH-200 Adhesive Caulk	12
TUF-TITE Products available for Roth RMT Tanks	
24" TAR-Tank Adapter Ring	12
POLYLOK Products available for Roth RMT Tanks	
3009-ARF Riser Adapter Ring	12
Application Guide-Pre-fabricated risers vs pipe risers	
Specifications and required attributes	13
STACK UP'S	
<ul style="list-style-type: none"> ● STAR-24 Threaded Riser System ● STAR-24 Threaded Riser System with Secondary Safety Lid Assembly ● Roth STAR-24TA/N12 Pipe Riser System ● Orenco Tank Adapter/Ultra-Rib-Pipe Riser System 	14 15 16 17
Notes and Warnings	18

Roth Risers STAR-24 System

Roth STAR-26 R6; HDPE Threaded Riser-6 in

Roth Part Number	STAR-24R6
Outside diameter	28.66 in
Inside diameter (Clear)	24.12 in
Height above threads	6.04 in
Wall thickness	0.20 in
Max riser stack height	36.00 in
Material	HDPE
Mfg. Process	Blow-molded
Attachment	Threads
Sealing primary	Foam Gasket
Sealing secondary	Mastic/ADH200
Application	RMT/PCC Tanks
STAR-24HPV	STAR-24MDB
Weight	7 lbs



The STAR-24R6 is a threaded 6 inch riser that is designed to mate directly to the manway(s) of the Roth RMT tank, add to an existing Roth STAR-24R6 or R12 riser to meet elevation requirements. The STAR-24R6 is also compatible with the STAR-24 HPV hanging pump vault and the STAR-24DB11 distribution box.

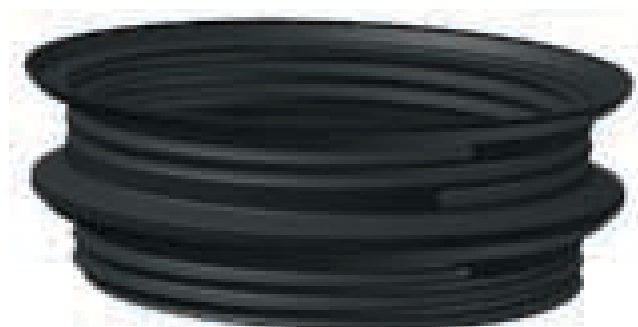
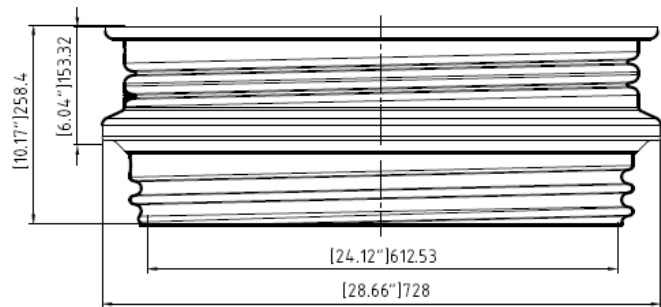

Roth Risers STAR-24 System

Roth STAR-24R12; HDPE Threaded Riser-12 in

Roth Part Number	STAR-24R12
Outside diameter	28.66 in
Inside diameter (Clear)	24.12 in
Height above threads	12.08 in
Wall thickness	0.20 in
Max riser stack height	36 in
Material	HDPE
Mfg. Process	Blow-molded
Pipe penetrations	(4) 5.50 in dia
Attachment	Threads
Sealing primary	Foam Gasket
Sealing secondary	Mastic/ADH200
Application	RMT/PCC Tanks
STAR-24HPV	STAR-24DB11
Weight	15 lbs

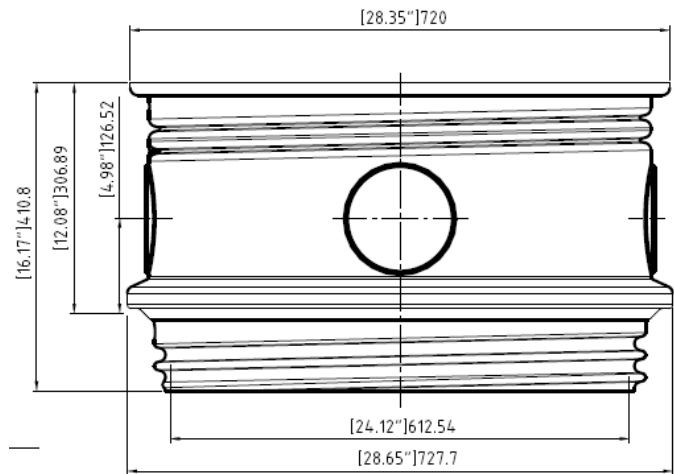
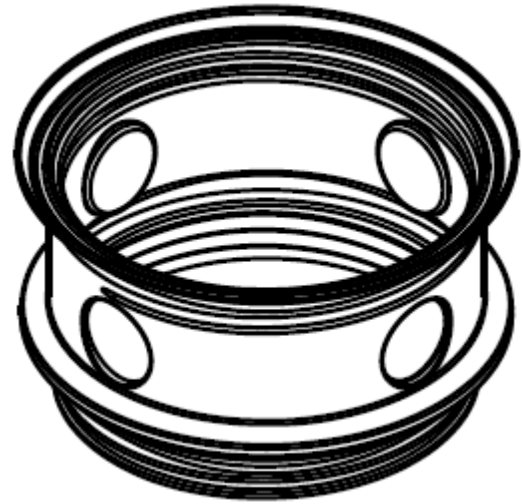

The STAR-24R12 is a threaded 12inch riser that is designed to mate directly to the manway(s) of the Roth RMT tank, add to an existing Roth STAR-24R6 or R12 riser to meet elevation requirements. The STAR-24R12 is also compatible with the STAR-24 HPV hanging pump vault and the STAR-24DB11 distribution box.



Roth Risers STAR-24 System

Roth STAR-24HPV; HDPE Threaded Hanging Pump Vault

Roth Part Number	STAR-24HPV
Outside diameter	28.35 in
Inside diameter (Clear)	NA
Height above threads	14.45 in
Wall thickness	0.20 in
Vault Section Height	34.25 in
Vault Section Capacity	43.5 Gal
Material	HDPE
Mfg. Process	Blow-molded
Pipe penetrations	(12) 5.50 in dia
Attachment	Threads
Sealing primary	Foam Gasket
Sealing secondary	Mastic/ADH200
Application	RMT-PCC Tanks
Weight	40 lbs

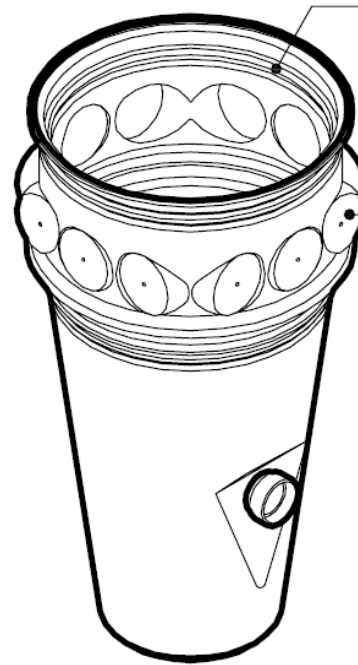

The STAR-24HPV is a threaded pump vault designed to directly install in the outlet compartment of the Roth RMT Tank and PCC tanks. It allows packaging of a pump, level controls, discharge piping and valves in a single module. The STAR-24HPV can be configured with screened inlet ports or a filter case for influent filtering.

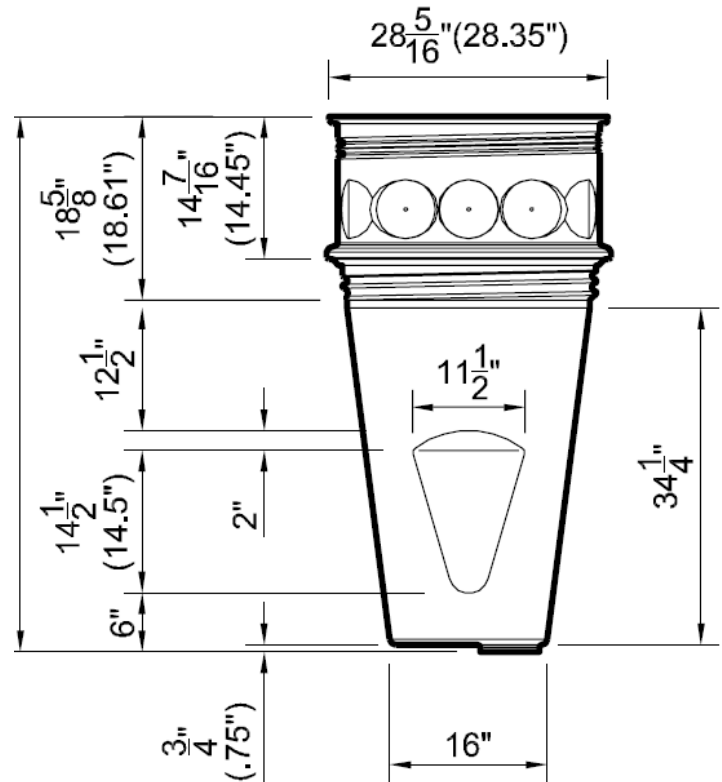

Roth Risers STAR-24 System

Roth STAR-24L Threaded Cover

Roth Part Number	STAR-24L
Outside diameter	29.76 in
Inside diameter	25.83 in
Wall thickness	Top 0.31 in
	Gusset 0.20 in
Height of Threads	4.72 in
Drive hole diameter	1.00"
Drive hole spacing	15.35" CL to CL
Material	HDPE
Mfg. Process	Blow-molded
Attachment	Threads
Sealing	Foam Gasket
Application	RMT/PCC Tank
STAR-24 HPV	STAR-24 Riser
STAR-24 DB11	
Weight	15 lbs

The STAR-24L is a threaded 24 inch lid that is the primary closure for of the STAR-24 system components. It is designed to install in the RMT tank, risers, HPV and the MD11 distribution box.

anti-slip-surface (Riffelblechdesign)

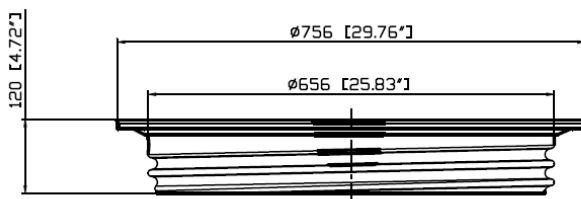
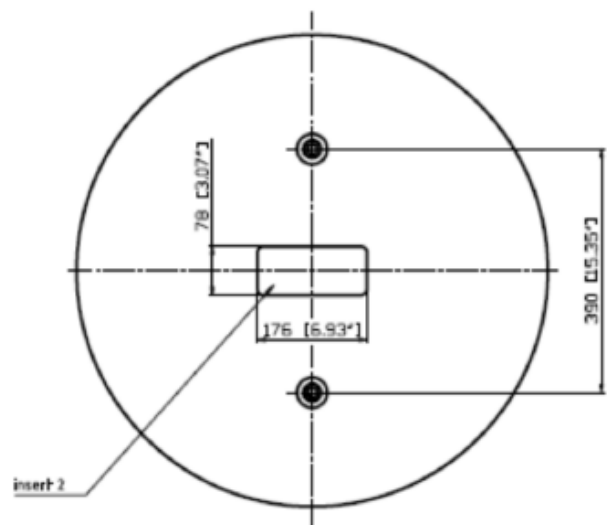
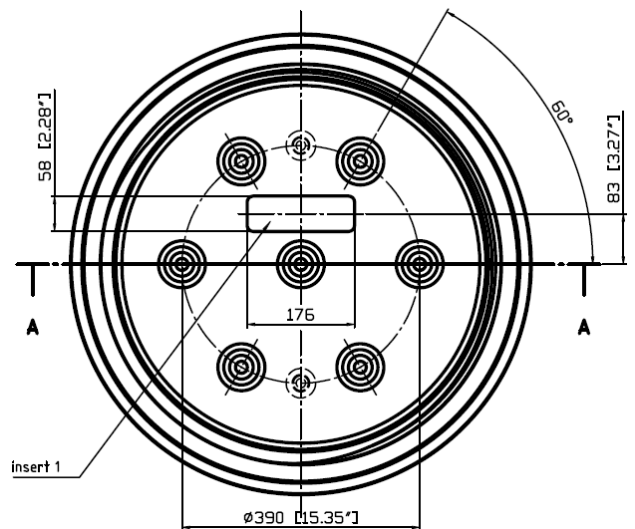
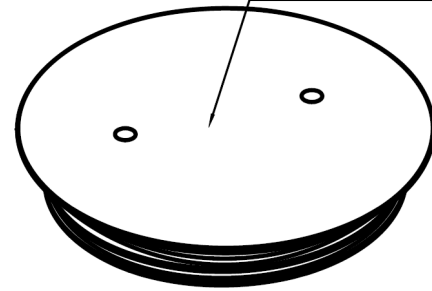

Roth Risers STAR-24 System

Roth STAR-24P Non-Threaded Plug Cover

Roth Part Number	STAR-24P
Outside diameter	29.76 in
Inside diameter	23.50 in
Wall thickness	Top 0.31 in
	Gusset 0.20 in
Height of "nose"	3.74 in
Material	HDPE
Mfg. Process	Blow-molded
Attachment	Gasket/screws
Sealing	Foam Gasket
Application	RMT/ PCC Tank
HDPE 24 in N12 Pipe Riser	
Weight	15 lbs

The STAR-24P is a non-threaded 24 inch plug that may be used as an alternate to the STAR-24L cover for direct installation in the RMT tank. It works in conjunction with the STAR-24TA tank adapter and user supplied 24 inch N12 HDPE 24 inch pipe to provide a pipe riser alternate to the STAR-24 riser system.

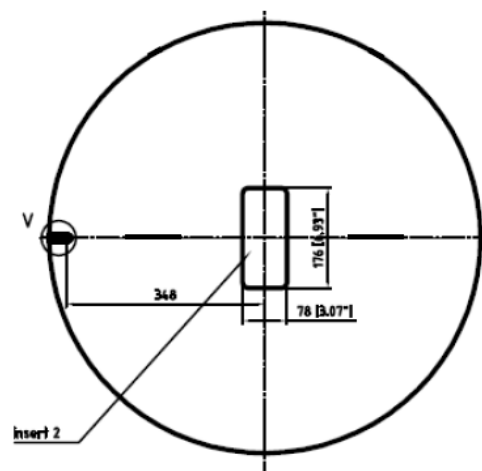
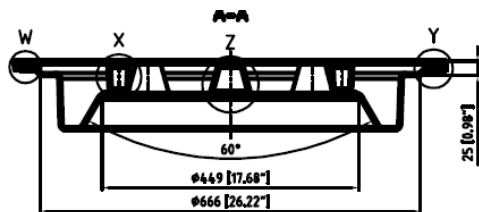
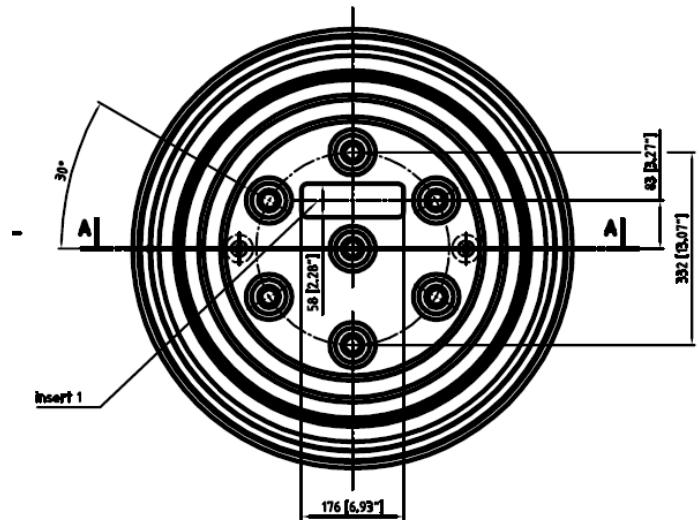
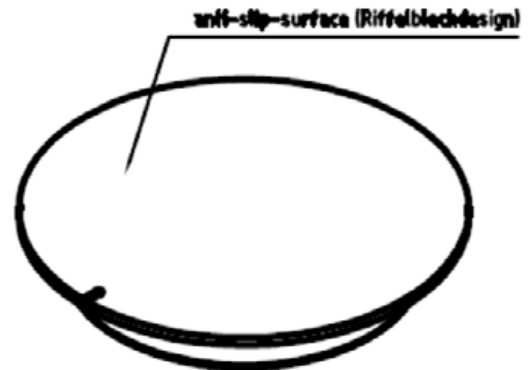

Roth Risers STAR-24 System

Roth STAR-18P Non-Threaded Plug Cover

Roth Part Number	STAR-18P
Outside diameter	23.77 in
Inside diameter	17.58 in
Wall thickness	Top 0.31 in Gusset 0.20 in
Height of "nose"	2.95 in
Material	HDPE
Mfg. Process	Blow-molded
Attachment	Gasket/screws
Sealing	Foam Gasket
Application	PCC Tank
HDPE 18 in N12 Pipe Riser	
Weight	10 lbs

The STAR-18P is a non-threaded 18 inch plug. It works in conjunction with the STAR-18TA tank adapter and user supplied 18 inch N12 HDPE 24 inch pipe to provide a pipe riser solution. Most often used to retrofit PCC tanks with a pipe riser.

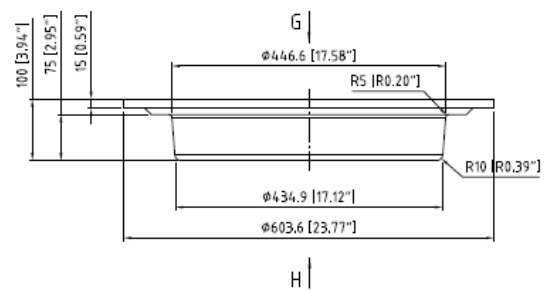
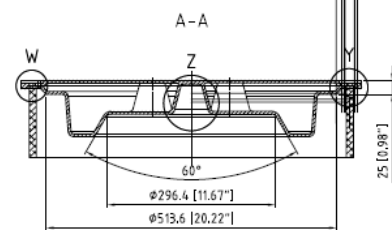
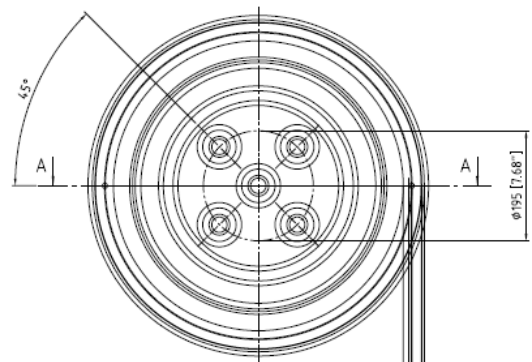
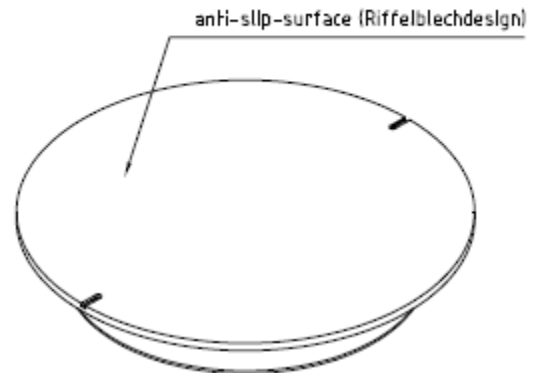
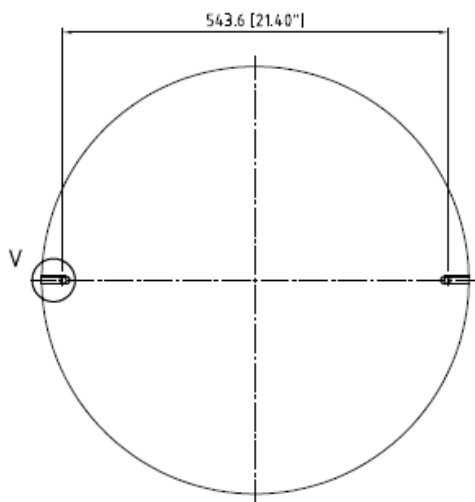

Roth Risers STAR-24 System

Roth STAR -24SSLA Secondary Safety Lid Assembly

Roth Part Number	STAR-24SSLA
Outside diameter	28.35 in
Inside diameter (Clear)	17.60 in
Height above threads	6.04 in
Wall thickness	0.20 in
Max riser stack height	36.00 in
Secondary cover	STAR-18P
Material	HDPE
Mfg. Process	Blow-molded
Attachment	Threads
Sealing primary	Foam Gasket
Sealing secondary	Mastic/ADH200
Application	STAR-24 system
Weight	20 lbs.



The STAR-24SSLA is a threaded secondary safety barrier intended to prevent unauthorized or accidental entry into wastewater tanks. It consists of a STAR-24R6 riser blow molded with a pan on the bottom with is then equipped with a STAR-18P plug to provide a secondary entry barrier. **The STAR-24SSLA must be installed with a STAR-24 riser between the tank and the SSLA to provide clearance for inlet/outlet tees**

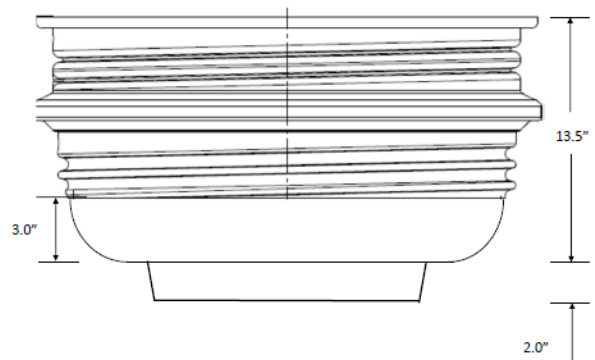
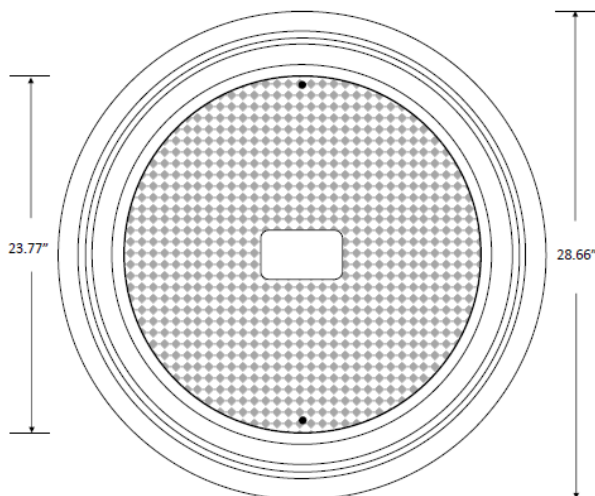
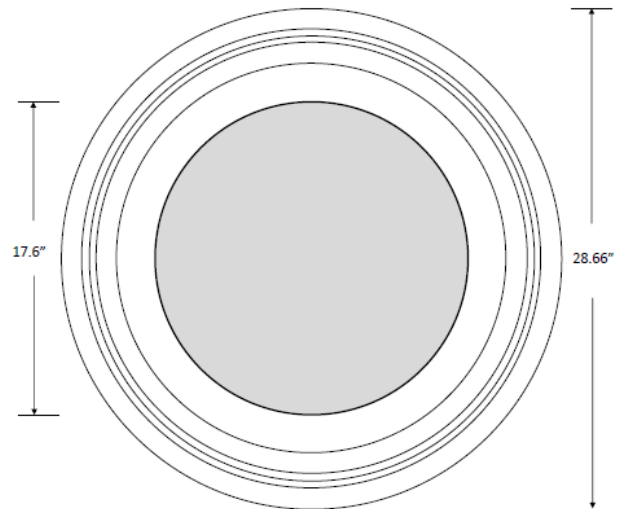

Roth Risers STAR-24 System

Roth STAR-24TA/STAR-18TA Tank adapters

Roth Part Number	STAR-24TA
Outside diameter	30.00 in
Inside diameter-clear	21.75 in
Outside diameter-nose	23.25 in
Wall thickness	0.50 in
Height of "nose"	2.20 in
No. of mounting holes	(8) 5/16 in ϕ
Bolt hole circle	29.00 in
Material	Polyurethane
Mfg. Process	Press-molded
Attachment	St Stl Screws
Sealing	Butyl Mastic
Application-	RMT/ PCC Tank
HDPE 24 in N12 or UltraRib 24 in Pipe Riser	
Weight	12 lbs.

Roth Part Number	STAR-18TA
Outside diameter	27.00 in
Inside diameter-clear	16.20 in
Outside diameter-nose	17.50 in
Wall thickness	0.50 in
Height of "nose"	2.20 in
No. of mounting holes	N/A
Bolt hole circle	N/A
Material	Polyurethane
Mfg. Process	Press-molded
Attachment	St Stl Screws
Sealing	Butyl Mastic
Application	PCC Tank
HDPE 18 in N12 Pipe Riser	
Weight	8 lbs.

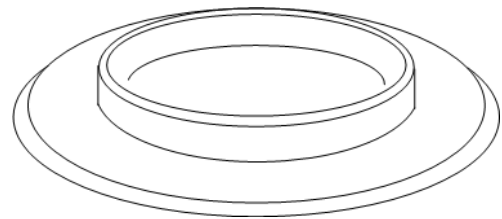
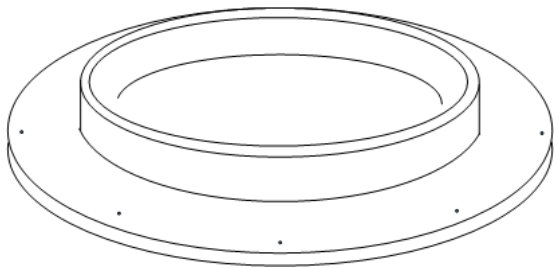

The STAR-24TA and STAR-18TA are tank to riser adapters to facilitate the mounting of a pipe riser to either a Roth RMT tank or in the case of the 18 in adapter, a PCC tank. The STAR-24TA is compatible with 24 in HDPE N12 Pipe as well as 24 in UltraRib PVC pipe. The STAR-18TA is compatible with 18 in HDPE N12 pipe.

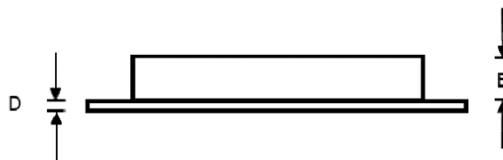
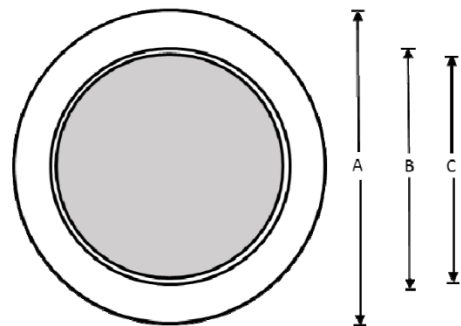

Roth Risers STAR-24 System

Roth STAR-24 Riser System Sealants

Roth Riser Gasket- PN RG24

- Primary Seal for STAR-24 System threaded joints
- Closed cell foam- $\frac{3}{4}$ " x $\frac{3}{4}$ " x 90"
- Pressure sensitive adhesive-one side
- Trim to fit
- **One gasket required for each threaded joint in the STAR-24 riser system**



Roth Butyl Mastic Seal- Riser-to-Tank Joint PN TJ-CS102

- Secondary seal for STAR-24 System threaded joints
- Primary seal for Tank Adapter installations
- Butyl Mastic Rubber Rope- $\frac{3}{4}$ " x $\frac{3}{4}$ " x 14ft
- Sufficient length to seal (2) riser to tank joints

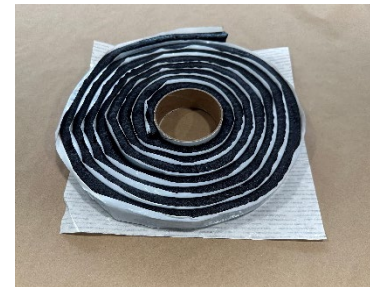

Roth Butyl Mastic Seal- Riser-to-Tank Joint PN PJ-CS665

- **Potable Water Rated for Cistern Tank Applications**
- Secondary seal for STAR-24 System Threaded joints
- Primary seal for Tank Adapter installations
- Butyl Mastic Rubber Rope- $\frac{5}{8}$ " x $\frac{3}{4}$ " x 15ft
- Sufficient length to seal (2) riser-to tank-joints



Roth Butyl Mastic Wrap- Riser-to-Riser Joint PN RJ-CS212

- Secondary seal for STAR-24 System threaded joints
- Butyl Mastic Backed Joint Wrap 4" x 50Ft
- Sufficient length to wrap and seal (6) riser-to-riser joints



Roth Plug Cover Seal Kit

- ID Tape gasket for pipe riser
- Stainless Steel Single Use Security Seal



Orenco Products available from Roth for Roth RMT Tanks

Orenco 24" ABS Riser-to-Tank adapter PN OR-ADP

Roth Part Number	OR-ADP
Outside diameter	30.00 in
Inside diameter-clear	19.00 in
Outside diameter-nose	23.25 in
Wall thickness	0.184 in
Height of "nose"	3.00 in
No of mounting holes	(8) 5/16 in ϕ
Bolt hole circle	29.00 in
Material	ABS
Mfg. Process	Inj. molded
Attachment	St Stl Screws
Sealing	Butyl Mastic
Application	Roth RMT
24 in UltraRib Pipe Riser	
Weight	5 lbs



The Orenco Tank Adapter is specifically designed to fit the Roth RMT tank to facilitate the mounting of a pipe riser to the RMT tank. It is compatible with 24 in UltraRib PVC pipe. **STEP system configurations that include the Orenco Biotube® vault require the use of the OR-ADP adapter for proper mounting and support of the vault.**

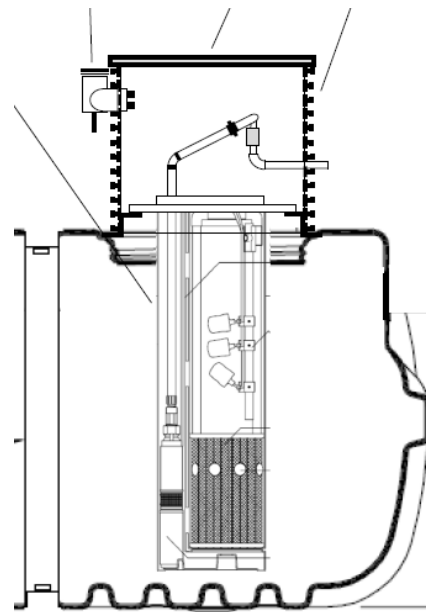

Orengo Products available from Roth for Roth RMT Tanks

Orengo Bolt Down Kit for Orengo Adapter PN OR-BDK

- Includes butyl mastic rope for Adapter-to-Tank seal
- Includes hex drive stainless steel screws to attach Adapter to tank manway opening
- (1) kit required for each adapter installation
- **The OR-BDK can be used to mount either the OR-ADP Or the Roth STAR-24TA tank adapter products.**



Orengo ADH200 Adhesive Caulk

- Moisture curing adhesive sealant, will not shrink while curing
- Cure time- Handling strength in 12 hours, full cure In 2-3 days
- Recommended quantity for each tank adapter joint- (2) tubes



Prefabricated riser products approved for use on Roth RMT Tanks

TUF-TITE Products available for Roth RMT Tanks

- PN 24-TAR Adapter Ring
- The 24-TAR Adapter ring is sized to fit the manway opening of the Roth RMT tank. Once in place, 24" TUF-TITE riser system components can be mounted on the Roth RMT. This riser to tank adapter has been tested and approved by Roth for use with Roth tanks.
- **Please contact TUF-TITE distribution directly for specific requirements and component availability.**



POLYLOK™ Products available for Roth RMT Tanks

- PN 3009-rtr24 Riser Adapter Ring
- The 3009-rtr24 Riser Adapter Ring is sized to fit the manway opening of the Roth RMT tank. Once in place, 20" or 24" POLYLOK riser system components can be mounted on the Roth RMT. This riser to tank adapter has been tested and approved by Roth for use with Roth tanks.
- **Please contact POLYLOK distribution directly for specific requirements and component availability.**



Application Guide-Pre-fabricated risers vs pipe risers

	STAR-24	STAR-24TA	Orenco ADP		
	Threaded Riser System	w Pipe Riser & Plug	w pipe Riser & Plug	Required attributes	Access interval
Residential septic, pump & dose	√	√	√	HWT	3-5 years
Residential septic, pump & dose w SSLA	√	√	√	HWT,AEP	3-5 years
Residential advanced treatment		√	√	CWT	1 year
Residential holding		√	√	CWT, FOA, DUR	30-90 days
STEP System Tanks		√	√	CWT, PCS, DUR	1 year
STEP w Orenco Biotube Pump Insert			√	CWT, PIS	1 year
Cistern-potable water		√	√	CWT, PWS	1 year
Grease Interceptor		√	√	CWT, FOA, DUR	2- 6 weeks
Rainwater harvesting	√	√	√	HWT	1 year
Riser stack height >3 ft		√	√	HWT, MSJ, DUR	NA

HWT- High degree of watertightness
 CWT- Critical degree of watertightness
 FOA- Frequency of access
 AEP- Accidental access prevention
 PCS- Pump/controls mechanical support
 PIS- Pump insert mechanical support
 PWS- Potable water sealants
 DUR- Durability
 MSJ- Minimum number of system joints

Reference Documents

- Installation Instructions-Roth RMT-Native Soils
- Installation Instructions-Roth Butyl Mastic 2008
- Installation Instructions-RGP STAR-24 Riser-RMT/ST-300 Pump Tank
- Installation Instructions Supplement-STAR-24 Riser System Installation and Sealing Methods
- Data Sheet-ConSeal CS-102
- Data Sheet-ConSeal CS-212
- Data Sheet-ConSeal CS-665
- Installation Instructions-RGP STAR-24TA-N12 Pipe Riser
- Tech Data Sheet-Orenco FRTA24 RVF Tank Adapters
- Tech Data Sheet-Adhesives and Dispensers for Orenco products (ADH200)

STACK UPS

Roth STAR-24 Riser System- 24 in dia., 18 in stack height- (max riser height 36 in)

(1) STAR-24R12 Riser, 12 in

(1) STAR-24-R6 Riser, 6 in

(1) STAR-24L Lid, 24 in

(3) RG24 Riser Gasket (1 included with the Lid)

(1) Roll TJ-CS102 Butyl Mastic Rope OR (2) Tubes ADH200 Adhesive

(1) Roll RJ-CS212 Butyl Mastic Wrap OR (1) Tube ADH200 Adhesive

Primary Riser Seal

Secondary Riser Seal

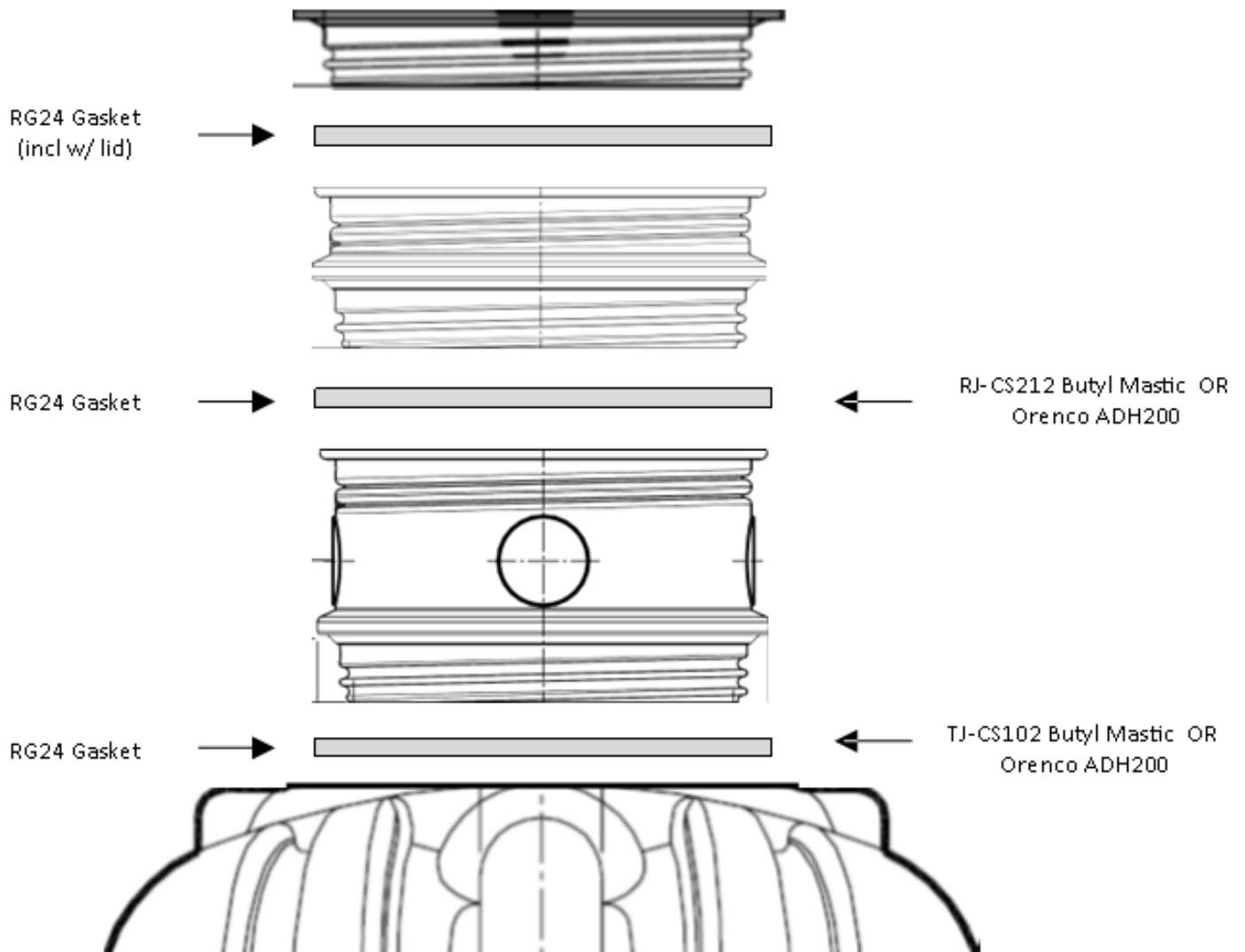

STACK UPS

Roth STAR-24 Riser System- 24 in stack height- With Secondary Safety Lid (max riser height 36 in)

(1) STAR-24R6 Riser, 6 in

(1) STAR24SSLA, Secondary Safety Lid Assembly

(1) STAR-24R12, Riser, 12 in

(1) STAR-24L Lid

(4) RG24 Riser Gasket (1 included with STAR-24L Lid)

(1) Roll TJ CS102 Butyl Mastic Rope OR (2) Tubes ADH200 Adhesive

(1) Roll RJ CS212 Butyl Mastic Wrap OR (2) Tubes AHD200 Adhesive

(Note- (1) STAR-24R6/12 must be installed below the STAR-24SSLA for plumbing clearance)

Primary Riser Seal

Secondary Riser Seal

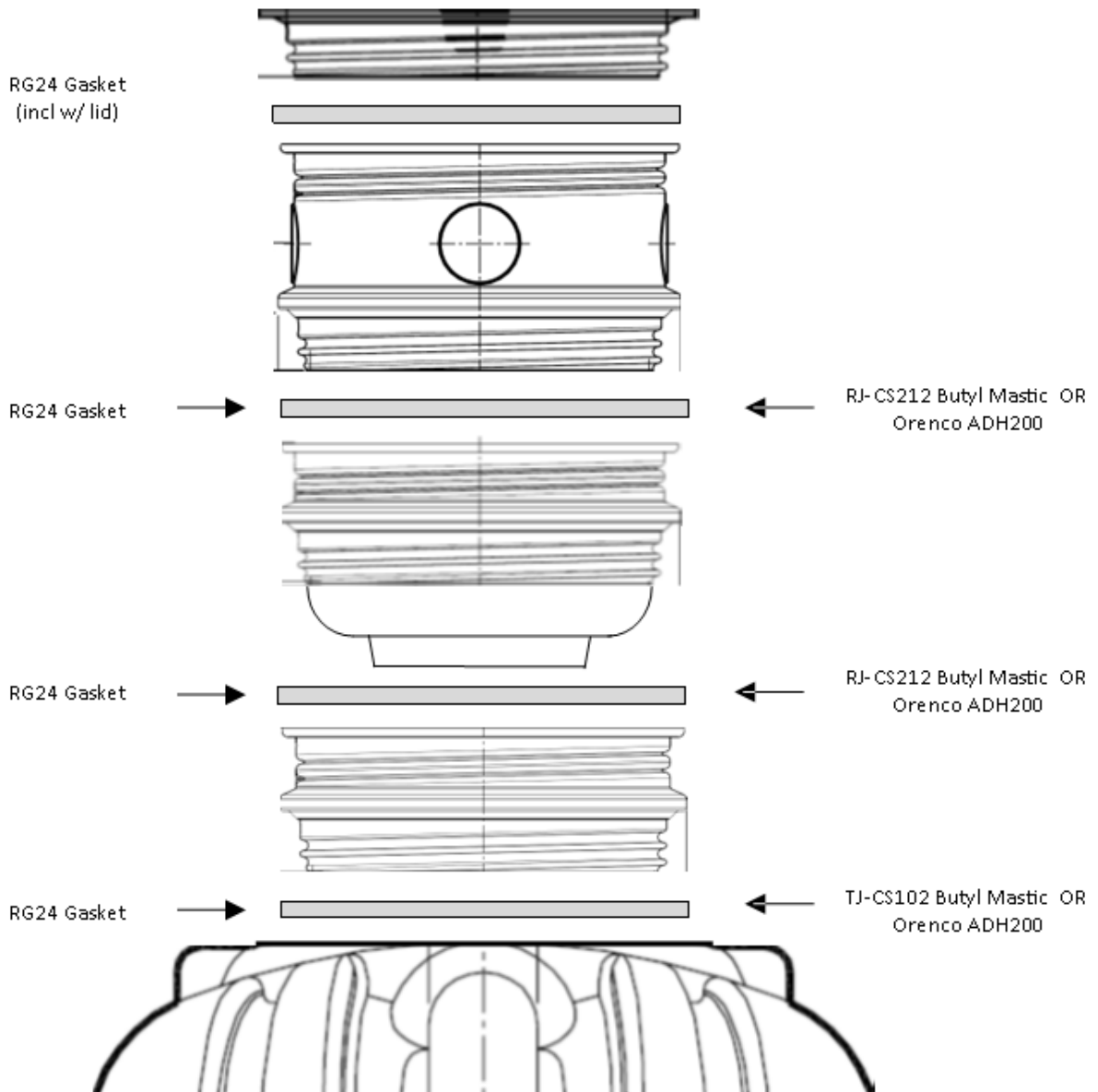

STACK UPS

Roth STAR-24TA/N12 24 in dia. Pipe Riser System

(1) STAR-24TA Tank Adapter

(1) OR-BDK Bolt Down Kit

(2) Tubes- ADH200 Adhesive

(1) Length 24 in HDPE N12 Culvert Pipe cut to required length (by others)

(1) STAR-24P Plug Cover with seal kit

NOTE:

For potable water service, substitute (1) roll, PJ-CS665 Mastic for the mastic included in the OR-BDK

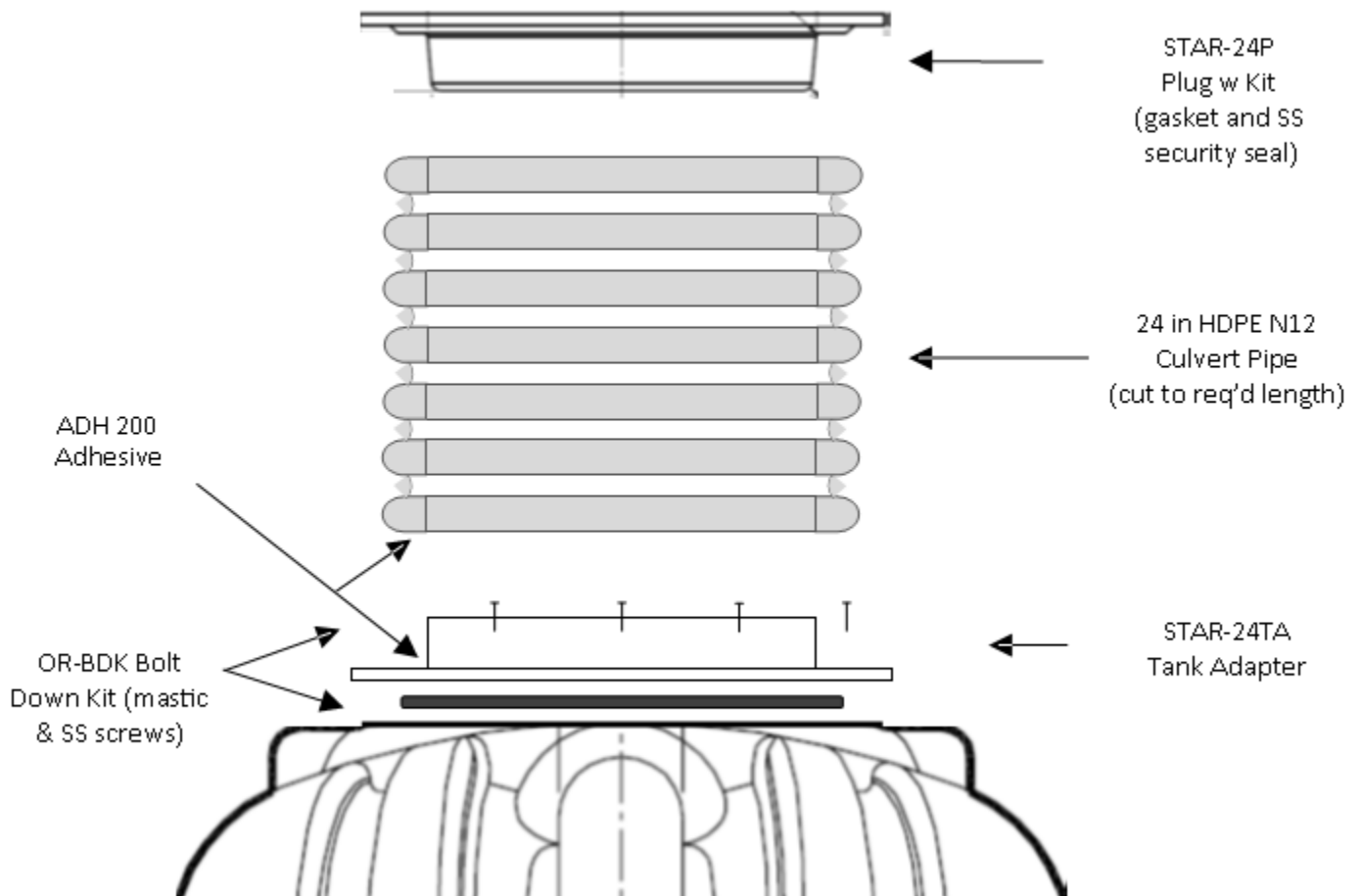

STACK UPS

Orenco Tank Adapter/Ultra-Rib-Pipe 24 in dia. Riser System

- (1) OR-ADP Tank Adapter
- (1) OR-BDK Bolt Down Kit
- (1) Length- 24 in Open Profile Ultra-Rib Pipe cut to required length (by others)
- (2) Tubes-ADH200 Adhesive
- (1) STAR-24P Plug Cover with Seal Kit

Note:

For potable water service, substitute (1) roll, PJ-CS665 Mastic for the mastic included in the OR-BDK

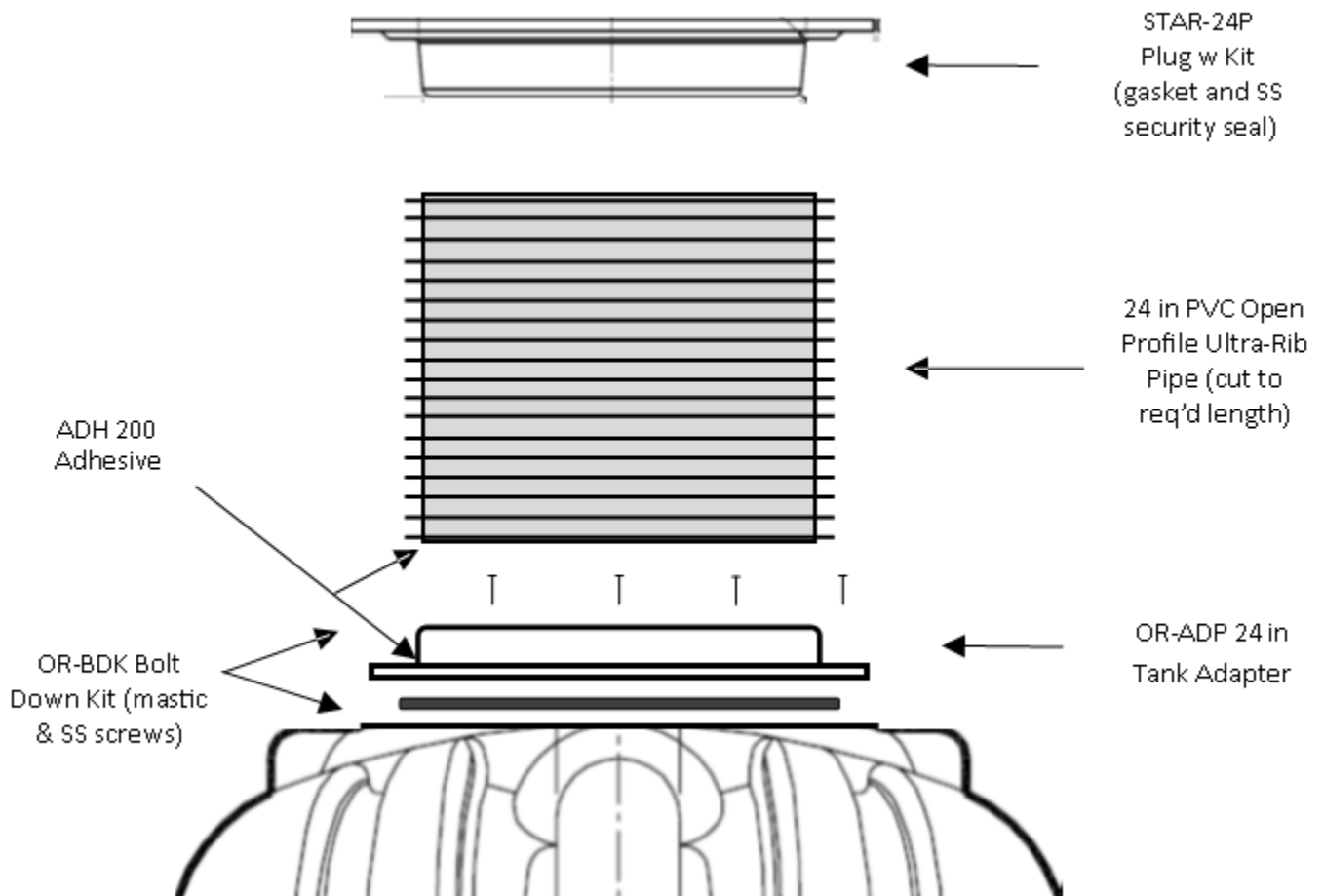

Installation Notes and Warnings

- *Installers shall comply with all federal, state and local regulations*
- *Verify that no underground utilities are located in the excavation area.*
- *Installation of buried tanks involves risk of excavation cave-in and the potential for personal injury or death. Required safety measures must be taken to ensure worker safety during tank installation and backfilling procedures.*
- *Roth RMT Tank and STAR-24 Riser System installations are not inherently rated for vehicular traffic. See separate supplemental installation instructions for guidance in constructing a traffic rated installation using Roth RMT products.*
- *Where saturated soil or seasonal high water tables are indicated between the bottom of the tank and the ground surface, see separate supplemental installation instructions for these site conditions.*
- *The maximum installed height for STAR-24 Riser Systems is 3ft or 36 inches.*
- *Internal tank wetted temperature should not exceed 140 Deg F.*
- *Secure tank access by installing stainless steel tamper resistant fasteners between the lid and riser and incorporating additional measures against accidental or unauthorized tank entry per the requirements of state and local regulations.*